

Year 7 NAPLAN  
Literacy & Numeracy  
Practice Tests A

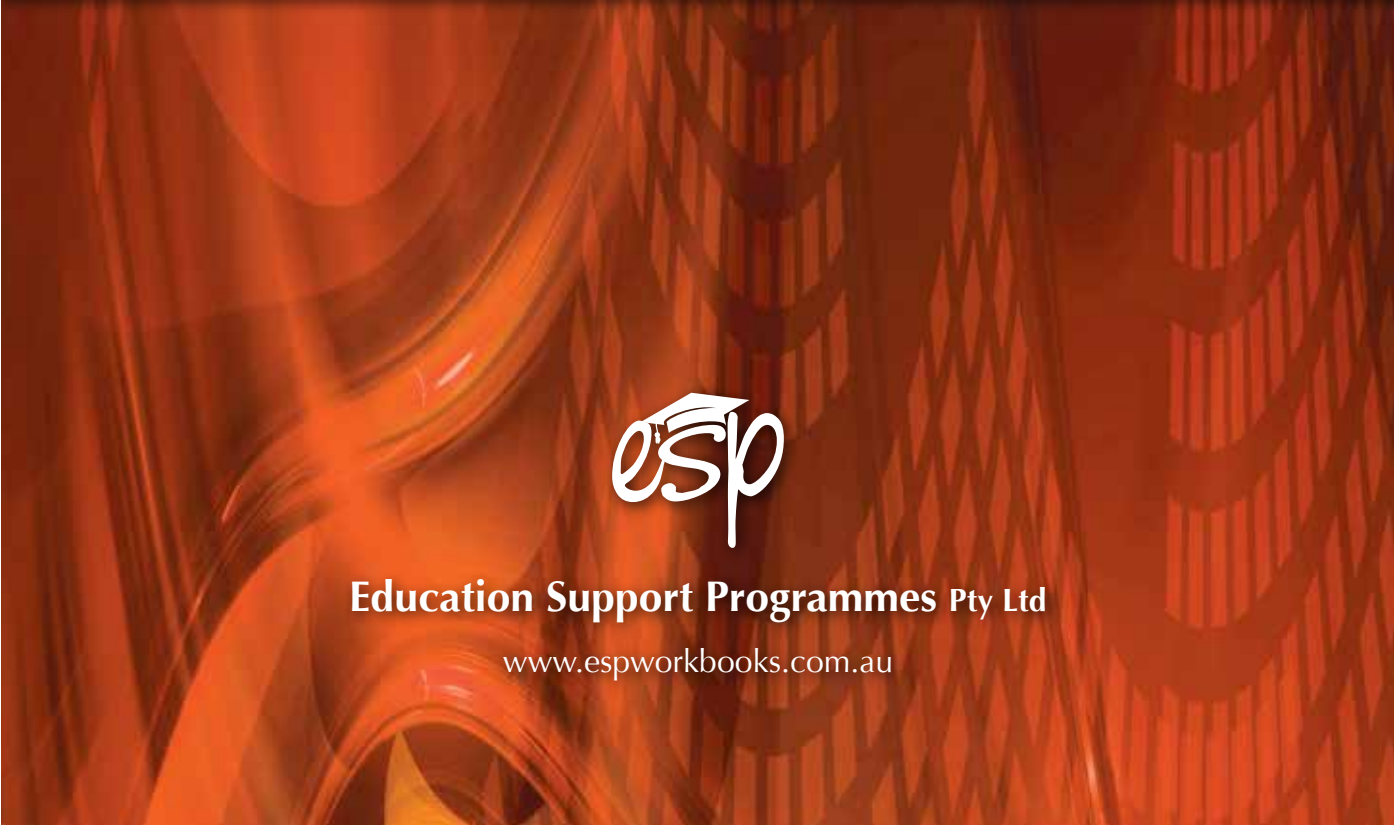

**Education Support Programmes Pty Ltd**

[www.espworkbooks.com.au](http://www.espworkbooks.com.au)



THIS PAGE IS INTENTIONALLY BLANK

 **NAPLAN-style Practice Questions**

**Remember to use a 2B pencil only.**

**The spelling mistake in the following sentence has been circled. Write the correct spelling for the circled word in the box.**

Jenny turned out the lite.

**P1**

**This sentence has one word which is used incorrectly. Write the word spelt correctly in the box.**

My friend brought a CD at the shop.

**P2**

**Use the correct word to complete the sentence.**

**P3** When will \_\_\_\_\_ sister arrive?

my

she

there

he





**Where do the two missing commas ( , ) go?**

**P4** Kim my cousin visited me at Easter

↑

↑

↑

↑



# NAPLAN-style Language Test A

Remember to use a 2B pencil only.

---

Read the text *Dame Joan Sutherland*. The circled words are spelling mistakes. Write the correct spelling for each circled word in the box.

Dame Joan Sutherland is **reconized** as one of **1**   
the world's greatest opera singers. Born in Sydney  
in 1926 she was first **tort** to sing by her mother. **2**   
Because of her **magnifisent** voice she was **3**   
called "La Stupenda", the Great One, by her  
adoring Italian **ordiences**. **4**

---

The circled words in the sentences below are spelling mistakes. Write the correct spelling for each in the box.

We are are having my **favorite** meal for **5**   
dinner tonight.

The queen's **rain** lasted many years. **6**

Jake likes to go to the **library** to work **7**   
on assignments.

The mango is a very **delisous** fruit. **8**

Jack was not **familiar** with his new **9**   
neighbourhood.

The lazy cow raised **it's** head and gazed at **10**   
us as we walked past.

We were excited when we **herd** Sarah had **11**   
been chosen to sing at the concert.

We have not decided **wether** we will go **12**   
to the movies or not.

---

---

**Read the text *The Creek*. The spelling mistakes have been circled. Write the correct spelling for each circled word in the box.**

**The Creek**

The creek near my house is a very **pieciful** 13

place. The **bows** of the willow trees touch the 14

water. There is a large **varity** of bird life. 15

**Somthink** I love to do is rock hop across 16

the stream.

---

**In each of the following sentences one word is spelled incorrectly. Write the correct spelling in the box.**

Question time in parlement is often noisy. 17

My mother wrote a check to pay for my new bike. 18

My grandfather is facinated by old machinery. 19

Mum was desparate to find a parking place at the station before the train arrived. 20

The accident occurred when the car's breaks failed. 21

It's important to strech your muscles before you play sport. 22

Lines of latitude are paralel. 23

The disgraced minister resined from the Government. 24

The winner will receve a trophy at the end of the carnival. 25

One way to solve difficult maths problems is to use the guess and check method.

26

The children whispered because they did not want to wake the sleeping baby.

27

It's difficult to find a word to rhyme with orange.

28

I find some Mathematics almost impossible.

29

My teacher encouraged me to join the choir.

30

31 Which of the following has the correct punctuation?

- Where are you going Mary called her father?
- "Where are you going?" Mary, called her father.
- "Where are you going, Mary?" called her father.
- "Where are you going Mary" called her father.

32 Which word or group of words correctly completes the sentence?

The new motor worked \_\_\_\_\_ than the old one.

efficiency

more efficient

efficiently

more efficiently

33 Two commas (,) have been left out of the sentence. Where should the missing commas go?

The girl who is in our chess club at school has a beautiful voice.



---

Read the text *Cochlear Ear*. Choose the best word from below to fill each gap.

### Cochlear Ear

When his father suddenly <sup>34</sup> \_\_\_\_\_ deaf Professor Graeme Clarke resolved to find a cure for deafness. After he had studied how electrical impulses <sup>35</sup> \_\_\_\_\_ the brain he invented the cochlear ear which has helped many deaf people to <sup>36</sup> \_\_\_\_\_ .

- |           |                              |           |                              |           |                             |
|-----------|------------------------------|-----------|------------------------------|-----------|-----------------------------|
| <b>34</b> | <input type="radio"/> became | <b>35</b> | <input type="radio"/> help   | <b>36</b> | <input type="radio"/> learn |
|           | <input type="radio"/> was    |           | <input type="radio"/> effect |           | <input type="radio"/> here  |
|           | <input type="radio"/> become |           | <input type="radio"/> affect |           | <input type="radio"/> think |
|           | <input type="radio"/> were   |           | <input type="radio"/> stop   |           | <input type="radio"/> hear  |
- 

**37** Which word or words correctly complete the sentence?

This is the \_\_\_\_\_ sunset I have ever seen.

- |                       |                       |                       |                       |
|-----------------------|-----------------------|-----------------------|-----------------------|
| beautiful             | most beautiful        | most beautiful        | more beautiful        |
| <input type="radio"/> | <input type="radio"/> | <input type="radio"/> | <input type="radio"/> |

**38** Choose the word that correctly completes the sentence.

\_\_\_\_\_ watch is on the bench?

- |                       |                       |                       |                       |
|-----------------------|-----------------------|-----------------------|-----------------------|
| Who's                 | Whose                 | Whom                  | Whos                  |
| <input type="radio"/> | <input type="radio"/> | <input type="radio"/> | <input type="radio"/> |

**39** Which one of these sentences is a question?

- When he is ready we will move on
- When will you arrive
- When we have moved the table the new dresser will fit
- When, not if, is the question

**40** Which of the following is correct?

- The girl that sang in the concert is my friend.
  - The cat who caught the mouse belongs to our neighbour.
  - The boy who we know won the race.
  - The car which won the race is owned by my friend.
-

---

Read the article *John Bradfield*. Choose the correct word to fill the gaps in the text.

## John Bradfield

John Bradfield was born in Sandgate, Queensland, in 1867. Although he is <sup>41</sup> \_\_\_\_\_ famous for designing and overseeing the building of the Sydney Harbour Bridge, he designed many other significant constructions in Australia. <sup>42</sup> \_\_\_\_\_ plan for an extensive underground railway system in Sydney <sup>43</sup> \_\_\_\_\_ only partly completed and his plan to divert water from North Queensland to the Darling River is still discussed. He died in 1943.

- |    |                             |    |                             |    |                                |
|----|-----------------------------|----|-----------------------------|----|--------------------------------|
| 41 | <input type="radio"/> the   | 42 | <input type="radio"/> He's  | 43 | <input type="radio"/> was      |
|    | <input type="radio"/> more  |    | <input type="radio"/> Their |    | <input type="radio"/> were     |
|    | <input type="radio"/> least |    | <input type="radio"/> Our   |    | <input type="radio"/> is being |
|    | <input type="radio"/> most  |    | <input type="radio"/> His   |    | <input type="radio"/> has      |
- 

44 Which word correctly completes the sentence?

I \_\_\_\_\_ to visit Strahan, a beautiful town on the west coast of Tasmania.

- will like
- had liked
- would like
- will have been liking

45 Which punctuation mark is missing from the sentence?

The band was to perform tonight  however the flight from Sydney was delayed because of fog.

- |                       |                       |                       |                       |
|-----------------------|-----------------------|-----------------------|-----------------------|
| comma (,)             | semicolon (;)         | elipses (...)         | colon (:)             |
| <input type="radio"/> | <input type="radio"/> | <input type="radio"/> | <input type="radio"/> |

46 Rewrite this sentence using direct speech.

Zac told Rachel that her mother would pick her up after school.

- "Zac, " said Rachel, "your mother will pick you up after school."
- Zac said, "that Rachel's mother would pick her up after school."
- Rachel's mother will pick up Zac and Rachel after school.
- "Your mother will pick you after school," Zac said to Rachel.



47 Which word correctly completes the sentence?

Luke said that \_\_\_\_\_ like to go to the movies today.

I'd

I'll

he'll

he'd

48 Which sentence is correct?

- The boys ran to get PE clothes from they're bags.
- The boys ran to get PE clothes from there bags.
- The boys ran to get PE clothes from their bags.
- The boys ran to get PE clothes from there's bags.

49 Which words correctly complete the sentence?

The girl \_\_\_\_\_ I gave the book failed to return it to the library.

to whom

to who

from whom

from who

50 Which sentence is correct?

- There is three galahs on the school oval.
- There's three galahs on the school oval.
- There are three galahs on the school oval.
- There was three galahs on the school oval.

51 Where do the two quotation marks (“ ”) go in this sentence?



The whole class stood and shouted, Happy Birthday! as John came into the room.

---

---

Read the text *Eddie Mabo*. Choose the right option to fill the gaps which have been left in the text.

### Eddie Mabo

While working at the James Cook University Eddie Mabo <sup>52</sup> \_\_\_\_\_ that the land on Murray Island which he <sup>53</sup> \_\_\_\_\_ as his was actually Crown Land. He was shocked.

In 1981, when he explained the aboriginal land inheritance system <sup>54</sup> \_\_\_\_\_ at a Land rights conference, a lawyer in the audience suggested that they should test the current laws.

The <sup>55</sup> \_\_\_\_\_ that aboriginal prior ownership was recognized in 1992, six months after Eddie Mabo died.

- 52  were told  
 is told  
 would have been  
 was told
- 53  had always regarded  
 had never regarded  
 has always regarded  
 was always regarding
- 54  while speaking  
 after speaking  
 by speaking  
 before speaking
- 55  result were  
 result is  
 result was  
 result had been
-



*Magazine*

### ***MAGAZINE ACKNOWLEDGEMENTS***

Walker Books Ltd

2008

87 Vauxhall Walk, London, SE11 5H

Cassandra Clare, *The Mortal Instruments (Book Two) City of Ashes*

Murdoch Books Pty Ltd

2005

Pier 8/9

23 Hickson Rd Millers Point NSW 2000

*Speeches that Changed the World*

Hodder Children's Books

2005

338 Euston Road, London NW13BH

Robert Muchamore, *The Killing*

Penguin Books Ltd,

2006

80 Strand, London WC2R0RL, England

Eoin Colfer, *Artemis Fowl and the Opal Deception*

*Early Chronicles of Cypress Land* compiled by Ailsa R. Dawson

Elanda Point Environmental Experience via Pomona

# Physical Activity PYRAMID

Teaming Up  
with **Good Nutrition**

It tells you: Physical activity is an essential part of every day.

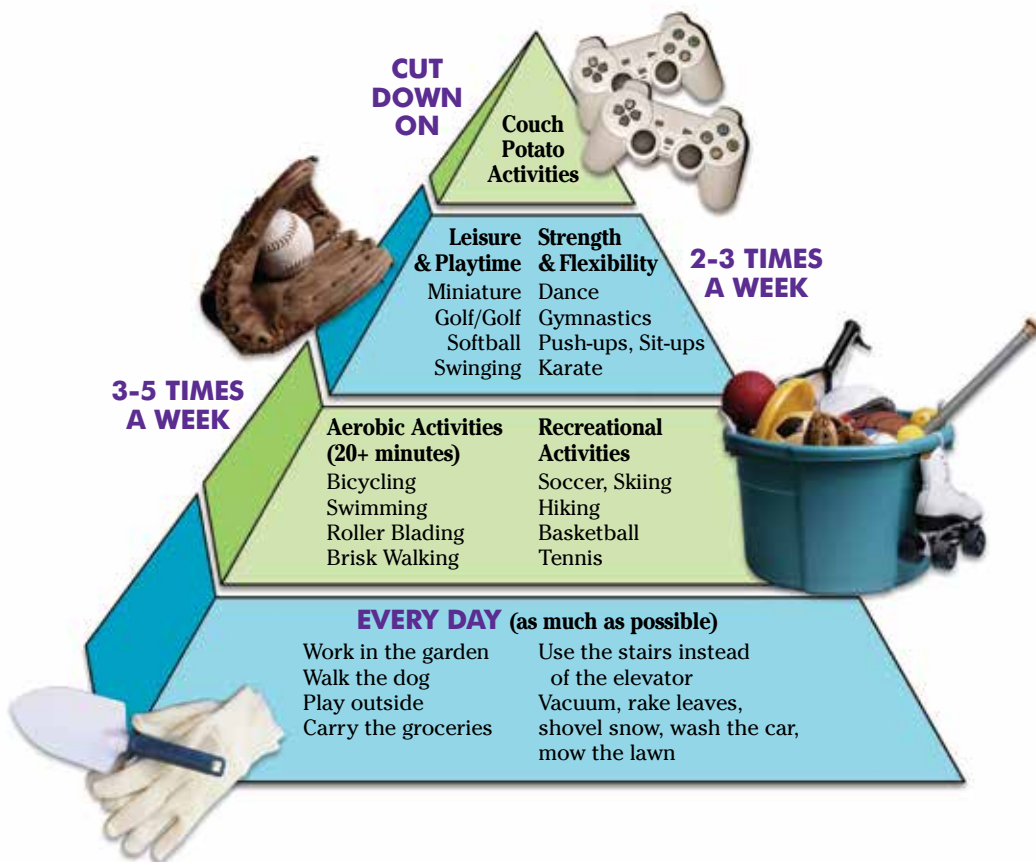

Regardless of your fitness level, there is a physical activity just right for you. The most exciting part of your day can be participating in a physical activity. Use the pyramid choices to help you get started.

Dissmores Food Court—<http://www.mydissmores.com/kids/pyramid>

WORK  
Well NC



*An extract from...*

# City of Ashes

*by Cassandra Clark*

Isabelle had been telling the truth; the institute was entirely deserted. Almost entirely anyway. Max was asleep on the red couch in the foyer when they came in. His glasses were slightly askew and he clearly hadn't meant to fall asleep. There was a book open on the floor where he had dropped it and his sneakered feet dangled over the couch's edge in a manner that looked as if it were probably uncomfortable.

Clary's heart went out to him immediately. He reminded her of Simon at the age of nine or ten, all glasses and awkward blinking and ears.

"Max is like a cat. He can sleep anywhere." Jace reached down and plucked the glasses from Max's face, setting them down on a squat inlaid table nearby. There was a look on his face Clary had never seen before—a fierce protective gentleness that surprised her.

"Oh, leave his stuff alone—you'll just get mud on it," said Isabelle crossly, unbuttoning her wet coat. Her dress clung to her long torso and water darkened the thick leather belt around her waist. The glitter of her coiled whip was just visible where the handle protruded from the edge of the belt. She was frowning. "I can feel a cold coming on," she said. "I'm going to take a hot shower."

Jace watched her disappear down the corridor with a sort of reluctant admiration. "Sometimes she reminds me of the poem. 'Isabelle, Isabelle, didn't worry. Isabelle didn't scream or scurry—'."

"Do you ever feel like screaming?" Clary asked him.

"Some of the time." Jace shrugged off his wet coat and hung it on the peg next to Isabelle's. "She's right about the hot shower, though. I could certainly use one."

"I don't have anything to change into," Clary said, suddenly wanting a few moments to herself. Her fingers itched to dial Simon's number on her cell phone, to find out if he was alright. "I'll just wait for you here."

"Don't be stupid. I'll lend you a T-shirt." His jeans were soaked and hung low on his hip bones showing a strip of pale tattooed skin between the denim and the edge of his T-shirt.

Clary looked away. "I don't think—"

"Come on." His tone was firm. "There is something I want to show you anyway."

Surreptitiously, Clary checked the screen on her phone as she followed Jace down the hall to his room. Simon hadn't tried to call. Ice seemed to crystallize inside her chest. Until two weeks ago, it had been years since she and Simon had had a fight. Now he seemed to be mad at her all the time.



*An extract from a speech by...*

## *Indira Gandhi* *New Delhi, 23 November 1974*

**Indira Gandhi was an Indian Prime Minister who was assassinated while in office.**

An ancient Sanskrit saying says, woman is the home and the home is the basis of society. It is as we build our homes that we can build our country. If the home is inadequate – either inadequate in material goods and necessities or inadequate in the sort of friendly, loving atmosphere that every child needs to grow and develop — then that country cannot have harmony and no country which does not have harmony can grow in any direction at all.

That is why women's education is almost more important than the education of boys and men. We—and by the 'we' I do not mean only we in India but all the world—have neglected women's education. It is fairly recent. Of course, not to you but when I was a child, the story of early days of women's education in England, for instance, was very current. Everybody remembered what had happened in the early days.

... Now, we have got education and there is a debate all over the country whether this education is adequate to the needs of society or the needs of our young people. I am one of those who always believe that education needs a thorough overhauling. But at the same time, I think that everything in our education is not bad, that even the present education has produced very fine men and women, specially scientists and experts in different fields, who are in great demand all over the world and even in the most affluent countries. Many of our young people leave us and go abroad because they get higher salaries, they get better conditions of work.

... One of the biggest responsibilities of educated women today is how to synthesize what has been valuable and timeless in our ancient traditions with what is good and valuable in modern thought. All that is modern is not good just as all that is old is neither all good nor all bad. We have to decide, not once and for all but almost every week, every month, what is coming out is good and useful to our country and what of the old we can keep and enshrine in our society. To be modern, most people think that it is something that it is a manner or dress or a manner of speaking or certain habits and customs, but that is not really being modern. It is a very superficial part of modernity.

... Now. For India to become what we want it to become with a modern, rational society and firmly based on what is good in our ancient tradition and in our soil, for this we have to have a thinking public, thinking young women who are not content to accept what comes from any part of the world but are willing to listen to it, to analyse it and to decide whether it is to be accepted or whether it is to be thrown out and this is the sort of education we want, which enables our young people to adjust to this changing world and to be able to contribute to it.







Research has shown that children who grow up in an organised environment are far more likely to succeed than children with excessive freedom surrounded by lack of structure. This environment is likely to have more influence on a child's ultimate success and happiness than his or her intelligence.

Living in an ordered environment encourages the child to develop ordered habits of mind so that it becomes natural for the child to think logically as well as maintain a physically tidy space. When logical thinking becomes a habit then many challenging tasks are simplified. The ancient Greek philosopher and father of modern thought, Aristotle, observed "We are what we repeatedly do. Excellence is not an act, but a habit."

A child armed with self discipline has a tremendous asset for addressing life's challenges. So many relational and personal problems can be avoided or solved when one has self-control. The child who is used to morning and evening routines, chores and family schedules is more likely to develop good self-control.

Self-control is illustrated by the way a person responds to everyday situations and the decisions which need to be made. A person with poor self-control will often react without thinking whereas a person who has good self-control will take time to decide on the best way to respond in any situation. Road rage is an example of poor self-control.

The self-discipline which develops as a result of organisation enables the child to more easily take control of his or her life and achieve dreams and goals. Research has shown that self-discipline developed in childhood is a good predictor of income, financial security, career prestige and physical and mental health.





*An extract from...*

# ARTEMIS FOWL AND THE OPAL DECEPTION

*by Eoin Colfer*

Mulch had left the stolen LEP shuttle at the theme-park gate. It had been a simple matter for Butler to disable the park's cameras and remove a half rotten section from the hemisphere's roof in order to effect the rescue.

When they got back to the shuttle, Holly powered up the engines and ran a systems check.

"What on earth were you doing, Mulch?" She asked, amazed by the readings the computer was displaying. "The computer says you came all the way down here in first gear."

"There are gears?" said the dwarf. "I thought this crate was automatic."

"Some jockeys prefer gears. Old fashioned, I know, but more control around the bends. And another thing, you didn't have to do that gas thing on the rope. There are plenty of stun grenades in the weapons locker."

"This thing has a locker too? Gears and Lockers. Well I never."

Butler was giving Artemis a field physical.

"You seem all right," he said, placing a massive palm over Artemis's chest. "Holly fixed up your ribs, I see."

Artemis was in a bit of a daze. Now that he was out of immediate danger, the day's events were catching up on him. How many times could one person cheat death in twenty-four hours? Surely his odds were getting short.

"Tell me, Butler," he whispered so the others wouldn't hear, "is it true? Or is it an hallucination?" Even as his words left his lips, Artemis realised that it was an impossible question. If it was all an hallucination then his bodyguard was a dream too.

"I turned down gold, Butler," continued Artemis, still unable to accept his own grand gesture. "Me. I turned down gold."

Butler smiled, much more the smile of a friend than a bodyguard. "That doesn't surprise me one bit. You were becoming quite charitable before the mind wipe."

Artemis frowned. "Of course you would say that, if you were part of the hallucination."

Mulch was eavesdropping on the conversation and couldn't resist a comment. "Didn't you smell what I shot those trolls with? You think you could hallucinate that, Mud Boy?"

Holly started the engines.

"Hold on back there," she called over her shoulder. It's time to go. The sensors have picked up some shuttles sweeping local chutes. The authorities are looking for us. I need to get us somewhere off the charts."





## *Uluru — historical, geographical and geological facts*

- Uluru is the official name. It was the name given by the Aborigines to the rock and the water hole on the top of the rock. Ayers Rock is still a commonly used name, especially outside Australia.
- Uluru is located very close to the geographical centre of Australia (25°20'41"S, 131°01'57"E). It is not the world's largest monolith. Mt Augustus in Western Australia is a larger but less significant rock. Uluru is 348 metres high, 3.6km long and 1.9km wide. The distance around the base of the rock is 9.4km and covers an area of 3.33km<sup>2</sup>. The top of Uluru is 862.5m above sea level and it extends several kilometres into the ground. The climb to the top is 1.6km.
- Uluru-Kata Tjuta (another large rock) National Park has a desert climate. It receives a surprising amount of rainfall for a desert, about 200–250mm a year. Like all deserts the area experiences extremes in temperature. Winter nights can be as cold as -8°C, and summer days as hot as 48°C. During the middle of summer the daily maximum averages 38°C.
- Both Uluru and Kata Tjuta are left overs from the huge sediment that was formed when sand was laid down in a basin about 900 million years ago. Material continued to collect at the bottom of this ancient sea bed. Five hundred and fifty million years ago the area was lifted and folded and mountain ranges formed. These ranges eroded in the following millions of years, leaving huge sediments at the bottom. About 300 million years ago the seas disappeared. The remaining sediment folded and fractured again. In this major process the sediment layers that now form Uluru were tilted, so that today they are at a 85°. This means Uluru and Kata Tjuta are the only visible tips of a massive underground rock slab. The rock is naturally grey but the iron content (feldspar) is rusting thus giving its red colour.



# Famous People's Thoughts about Aging and the Aged

“You will be courteous to your elders who have explored to the point from which you may advance; and helpful to your juniors who will progress farther by reason of your labours.”

*Abbott L Lowell (for 24 years he was president of the famous Harvard University in America)*

“Children have never been very good at listening to their elders, but they have never failed to imitate them.”

*James A. Baldwin (a famous American Novelist)*

“Resolve to be tender with the young, compassionate with the aged, sympathetic with the striving, and tolerant with the weak and the wrong. Sometime in your life you will have been all of these.”

*Dr. Robert H. Goddard (American rocket engineer 1882–1945)*

“It was once said that the moral test of government is how that government treats those who are in the dawn of life, the children; those who are in the twilight of life, the elderly; and those who are in the shadows of life, the sick, the needy and the handicapped.”

*Hubert Humphrey (Vice-President of the United States of America in the 1960s)*

“There is a fountain of youth: it is your mind, your talents, the creativity you bring to your life and the lives of people you love. When you learn to tap this source, you will truly have defeated age.”

*Sophia Loren (famous Italian Actress who won 50 International Film awards in her career.)*

“Age is...wisdom, if one has lived one's life properly.”

*Miriam Makeba (South African woman whose work helped remove Apartheid, racial segregation, from South Africa)*

“Age should not have its face lifted, but it should rather teach the world to admire wrinkles as the etchings of experience and the firm line of character.”

*Ralph B. Perry (famous American philosopher and professor)*

“A test of a people is how it behaves towards the old. It is easy to love children. Even tyrants and dictators make a point of being fond of children. But the affection and care for the old, the incurable, the helpless are the true gold mines of a culture.”

*Abraham Heschel (a leading Jewish Rabbi and philosopher)*





# *The River and the Lakes*

## *Early Chronicles of Cypress Land: Cooloola*

*(compiled by Ailsa R. Dawson)*

The year has made its cycle once more, and September is on the way bringing its wealth of spring wildflowers. Bird life abounds and Lakes Werin and Doonella have come into their own again, for the pelicans are beginning to return, and the black swans have almost overnight taken possession of the shallow lake waters.

It is an amazing sight to see scores of wild black swans and their plain brown cygnets tranquilly fishing, resting and snoozing within a few yards of the busy highway from Tewantin over Doonella Bridge. The young ones move in close to the shore, ignoring completely the noise of countless vehicles; but let a few pedestrians move purposefully towards the water's edge and note the withdrawal strategy! As if at a general's command, the babies begin to scurry from the edge of the lake, swimming in a close but quick withdrawal order towards the older birds. These too, in obedience to an unuttered command, lift sleepy heads from wings, curve graceful necks, and with an amusingly pompous air, fan out in a movement which surrounds the fleeing cygnets, and with a hardly perceptible turn, the whole fleet makes a majestic and unhurried departure to the safety of the middle of the lake.

The river and the lakes it drains form a unique series of waterways and although busy holiday resorts have sprung up in the lower reaches, the upper reaches of the river and lakes remain much as they were when the aborigines knew them. Acres of plant life, varying from scanty casuarinas, through mangled wallum swamps to the great forests on the higher land, make this area one of tremendous interest to the naturalist.

In spring, innumerable wildflowers cover the wallum, but the habit of growth of many in the peaty ooze of tangled wallum country makes them difficult to access. Just as well perhaps, for wildflower treasure seems to have an irresistible temptation for the average wayfarer to pluck, and then leave lying beside the road.

Wildflowers from this area do not take kindly to plucking, and their elusive beauty should remain where their charm is enhanced by their natural setting. The naturalist will find that though August and September bring lavish displays of banksia, hovea, wattles, swamp lilies ("silk hankies"), golden pea and showy bridal bush, there is seldom a month when the bush will not yield some floral treasure for the discerning wanderer.



 NAPLAN-style Reading Test A

Remember to use a 2B pencil only.

Time available: 65 minutes

Examine the *Physical Activity Pyramid* on page 1 of the magazine and answer questions 1 to 6 below.

- 1 The diagram illustrates
  - how to be happy.
  - everyday ways to keep physically active.
  - how to be healthy.
  - how to become a top sportsperson.
  
- 2 The physical activities are in the form of a pyramid because
  - everybody should play sport to keep fit.
  - the top of the pyramid lists the most important activities.
  - the width of the pyramid illustrates how often the activity should be done each week.
  - the base of the pyramid lists things that are a part of everyday life.
  
- 3 The information on the pyramid is intended for
  - children.
  - teachers.
  - parents.
  - everybody.
  
- 4 If you are physically active
  - you will be healthy.
  - you need to be good at sport.
  - you will be healthy if you eat good food as well.
  - you will always be happy.
  
- 5 Which of the following is a couch potato activity?
  - using the lift
  - tidying the room
  - playing mini-golf
  - walking the dog

6 Which of these activities should be done almost every day?

- dance
  - golf
  - strengthening activities
  - recreational activities
- 

Read *City of Ashes* on page 2 of the magazine and answer questions 7 to 12.

7 Isabella took a shower because

- she was muddy.
- she felt hot and sweaty.
- she felt cold.
- she felt a cold coming on.

8 The reason why Max was asleep on the red couch was

- he planned to sleep there.
- there was no room anywhere else.
- he fell asleep waiting for his friends.
- he was very comfortable there.

9 What did the writer mean by *her heart went out to him*?

- She felt affection for him.
- She felt sorry for him.
- She was in love with him.
- She thought his ears were big.

10 How did Jace feel when he saw Max?

- |                       |                       |                       |                       |
|-----------------------|-----------------------|-----------------------|-----------------------|
| angry                 | happy                 | caring                | concerned             |
| <input type="radio"/> | <input type="radio"/> | <input type="radio"/> | <input type="radio"/> |

11 *Jace watched Isabelle walk away from him with a sort of reluctant admiration.*

By this the author means

- he admired her for the wrong reasons.
- he admired her even though she annoyed him.
- he didn't really admire her but made it appear as though he did.
- he knew he shouldn't admire her but he still did.

12 Surreptitiously means?

- |                       |                       |                       |                       |
|-----------------------|-----------------------|-----------------------|-----------------------|
| noisy                 | worried               | quickly               | secretively           |
| <input type="radio"/> | <input type="radio"/> | <input type="radio"/> | <input type="radio"/> |
-

---

**Read the extract from Indira Gandhi's speech from *Famous Speeches of the World* on page 3 of the magazine, and answer questions 13 to 18.**

**13** What does Indira Gandhi believe "being modern" means?

- All ancient traditions should be valued.
- New ideas that are useful to a country should be adopted.
- Indians should adopt the customs of the West.
- India should accept all the new ideas from the outside world.

**14** Gandhi suggests that the vital element in the development of a healthy country is

- a loving, friendly atmosphere.
- material wealth.
- harmony.
- caring wives and mothers.

**15** Indira Gandhi believes that education always needs a thorough overhauling. Why does she say this?

- The present system is neglecting women.
- Education must always fulfill the needs of young people.
- The present system is a bad one.
- India is falling behind other countries.

**16** In India educated women need to

- make sure Indian traditions are not lost in modern society.
- ensure that new ideas are embraced quickly.
- become famous scientists.
- combine modern thought with what is good in Indian traditions.

**17** Why does Indira Gandhi believe India needs a thinking public?

- Indians should be ready to accept all the new ideas from all over the world.
- Indians should analyze and accept the good ideas from all over the world.
- Indians should ensure that Indian traditions should survive.
- Educated Indians should reject modern ideas because they will destroy Indian culture.

**18** The basis of Indian culture is

- the home.
- education.
- scientific discoveries
- understanding modern ideas.

---

Read *Developing Self Discipline* on page 4 of the magazine and answer questions 19 to 23.

19 Research shows that giving children a lot of freedom

- helps them to develop self discipline.
- helps them to be successful in life.
- lessens their chance of future success.
- creates a good environment for growth.

20 The most important thing for future happiness is

- intelligence.
- parental discipline.
- freedom.
- an organised environment.

21 According to the text, what is one indication that a person has good self-control?

---

---

---

22 The main reason why children should do regular household chores is

- to keep the house tidy.
- to take the pressure off busy parents.
- to develop a sense of responsibility.
- to be a good example to their brothers and sisters.

23 Explain what Aristotle means when he says *Excellence is not an act, but a habit.*

---

---

---

---



---

Read *Artemis Fowl and the Opal Deception* on page 5 of the magazine and answer questions 24 to 28 .

24 Why did Artemis drive in first gear?

- He did not know there were gears.
- He did not know how to change gears.
- He needed to travel quietly and slowly.
- He had no need to speed.

25 His question to Butler was an impossible one because

- he knew Butler did not have an answer.
- Butler would not answer truthfully.
- only Holly knew the answer.
- it was possible that Butler did not exist.

26 Artemis did not believe Butler because

- he had been untrustworthy in the past.
- he felt Butler was not a true friend.
- he thought Butler was part of the hallucination
- Artemis knew he was lying about the gold.

27 How often did Mulch drive the shuttle?

- |                       |                       |                       |                       |
|-----------------------|-----------------------|-----------------------|-----------------------|
| never                 | seldom                | often                 | always                |
| <input type="radio"/> | <input type="radio"/> | <input type="radio"/> | <input type="radio"/> |

28 What evidence did Mulch offer to prove that Artemis was not having an hallucination.

- The authorities were after them.
  - Hallucinations don't have smell.
  - He had cheated death several times already that day.
  - The trolls could not be a part of an hallucination.
-

---

Read about *Uluru* on page 6 of the magazine and answer questions 29 to 33.

29 According to the text, why was Ayers Rock renamed Uluru in 1985?

- No one remembered who Ayer was.
- It was a way of helping the tourist industry.
- The rock was returned to the traditional owners.
- The government decided to give it an aboriginal name.

30 From your reading of the text which of the following statements about Mt Augustus is not true?

- It is in an area not popular with tourists.
- It was not as spectacular as Uluru.
- It has a significant geographical position.
- It is not a part of the aboriginal tradition.

31 Uluru and Kata Tjuta are

- two equally famous monoliths.
- part of one large rock
- different in colour; one is grey while the other is red.
- made from volcanic lava.

32 Which of the following is not true?

- Uluru was once at the bottom of the ocean.
- Uluru was formed nine hundred million years ago.
- Feldspar makes Uluru look red.
- Fractures caused Uluru to tilt 85°.

33 What evidence is there to support the statement that Uluru does not have a typical desert climate?

- It has a high altitude.
  - It gets very cold.
  - It receives more rainfall than a typical desert.
  - It is not typical that such a huge rock is in the desert.
-

---

**Read *Famous People's Thoughts about Aging and the Aged* on page 7 of the magazine and answer questions 34 to 38.**

**34** According to the text a good moral test of government is the way

- It keeps peace in the country.
- it looks after the sick, handicapped and needy
- it maintains the wealth of the country.
- It makes it easy for people to travel around the country.

**35** James Baldwin's saying means

- The young always try to do the opposite to the previous generation.
- The young feel they know better than their elders but find their elders are often right.
- Younger generations tend to repeat the good and bad of their elders.
- Old people do not have anything to teach younger generations because they don't keep up with modern ideas

**36** Sophia Loren says that age does not matter if

- you keep your health.
- you have your family around you.
- your mind is still active.
- you continue to use your talents for the good of others and yourself.

**37** Wrinkles should be

- |                       |                       |                       |                       |
|-----------------------|-----------------------|-----------------------|-----------------------|
| removed               | valued                | ignored               | ridiculed             |
| <input type="radio"/> | <input type="radio"/> | <input type="radio"/> | <input type="radio"/> |

**38** What reason does Doctor Goddard give for the value of compassion, sympathy and tolerance.

---

---

---

**39** Lowell believes

- if you are courteous to your elders you will be treated well when you are older.
- each generation learns from the mistakes of those who come before.
- each generation plays its part in the progress of humankind.
- if you have lived properly you will become wise.

---

Read *The Rivers and the Lakes* on page 8 of the magazine and answer questions 40 to 43.

40 The rivers and lakes have come into their own again because

- rain has filled the lakes.
- flowers are growing.
- more birds are at the lakes
- it is September.

41 The black swans and their cygnets are disturbed by

- countless vehicles.
- a few pedestrians.
- pelicans.
- birds of prey.

42 What does the author mean by *in obedience to an unuttered command*?

- responding to the warning cries
- fleeing from danger
- responding automatically
- the cygnets imitated their adult companions

43 What are the most interesting aspects of the lakes for the naturalists?

- the many varieties of birdlife
- the variety of wildflowers
- the mangled wallum swamps
- the abundant variety of wildlife

44 When do wildflowers flourish in the Cooloola Lakes district?

- all year round
  - in August and September
  - in spring
  - in autumn
-

## NAPLAN-style Numeracy Test A (calculator allowed)

Remember to use a 2B pencil only.

### WARM-UP



(calculator allowed)

- 1 The answer to  $63\,721 \div 307$  (to one decimal place) is

212.8

207.6

207.5

212.4

- 2 The  $\sqrt{326}$  lies between

16 and 17

17 and 18

18 and 19

19 and 20

- 3 The next number in the sequence 7, 12, 17, 22, .... is .

### PRACTICE TEST



(calculator allowed)

- 1 The following graph shows the serves returned by Kali during her first four days of practice in which her coach hit serves to her.

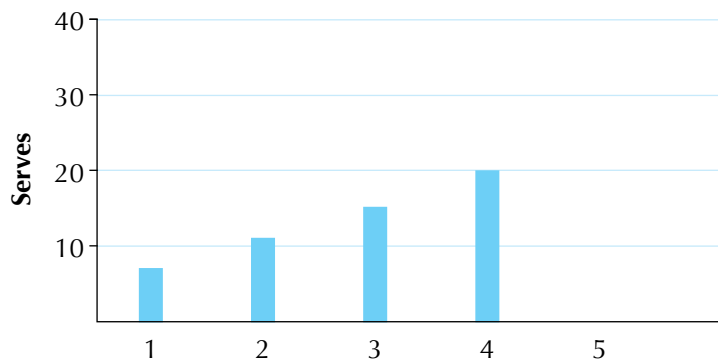

Assuming she improves at the same rate, the number of serves most likely to be returned on day 5 is

18

20

23

27



- 2 The census in 2011 found that the population of Australia was 21 507 717. This was an 8.3% increase since 2006. If the same rate continues, what is the expected population in 2016?

23 292 858



21 832 632



28 321 367



25 832 832



3

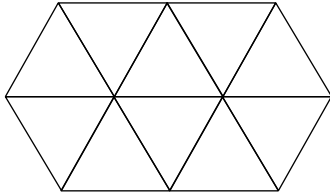

If this shape is made up of equilateral triangles with all sides equal to 2.5cm, the perimeter of the shape is

20cm



42.5cm



47.5cm



50cm



- 4 75% of visitors to the exhibition said it was the best they had seen. If 12 000 people saw the exhibition, how many thought it was not the best they had seen?

9 000



3 000



8 000



10 000



- 5 At the local high school there are 192 year 8 students. 25% of these students play soccer at school on sports day. If 25% of these students forgot their sports clothes, the number who played soccer was

students

Examine the table below and use it to answer questions 6, 7, 8 and 9.

The table shows the number of students using the tuckshop at morning tea during the week.

	Week 1	Week 2	Week 3	Week 4	Week 5
Monday	145	125	120	135	115
Tuesday	95	86	90	78	88
Wednesday	102	88	78	90	96
Thursday	114	90	78	84	90
Friday	120	100	92	121	112

- 6 The least popular day at the tuckshop is

Tuesday



Wednesday



Thursday



Friday



7 The mean number of students who used the tuckshop on Monday was

- 115                      120                      125                      128
- 

8 The range of the number of students on all days is

- 33                      67                      78                      107
- 

9 What is the mode of distribution of students per day?

- 78                      88                      120                      90
- 

10 Daniel can buy

- a) a 200 page exercise book for \$3.20, or  
b) a pack of 5 books (each with 48 pages) for \$3.50.

Which is the better value?

Use the following information to answer questions 10 and 11.

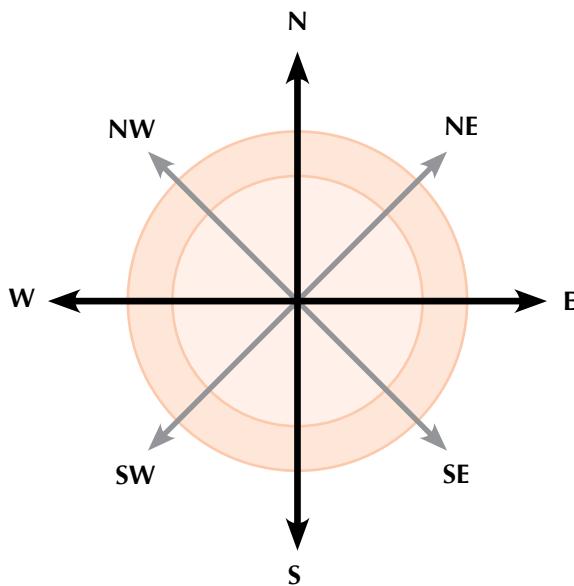

11 The angle between East and North-West in a clockwise direction is

- 135°                      180°                      225°                      240°
- 

12 If Keiran walked 5km North and then 5km East, the direction to his starting point from his present position would be

- South-East                      North-West                      North-East                      South-West
-

13 Kate shares equally a prize of \$120 with four friends. What is her share?

\$30



\$24



\$25



\$20



14 What is the answer to  $8.4 \div 0.7$

0.12



1.2



12



14



15 Which number is exactly half-way between  $3 \frac{1}{8}$  and  $5 \frac{3}{8}$ ?

$1 \frac{1}{8}$



$3 \frac{7}{8}$



$4 \frac{3}{8}$



$4 \frac{1}{4}$



16 A bag of lollies contains 6 red ones. What fraction of lollies are red if the bag contains 30 lollies?

$\frac{1}{6}$



$\frac{1}{5}$



$\frac{4}{5}$



$\frac{5}{6}$



17  $72 \div \triangle = 40$

What is the value of  $\triangle$ ?

$1 \frac{4}{5}$



$\frac{5}{9}$



$\frac{8}{12}$



$1 \frac{1}{2}$



18 Holly has a cherry tree. On Monday she picks 0.75kg of cherries, on Tuesday she picks 1.24kg and on Wednesday she picks 0.92kgs. The total weight of the cherries picked is

3.21kg



2.77kg



2.91kg



3.02kg



19 Which set of fractions is in order from largest to smallest?

$\frac{1}{10}, \frac{4}{20}, \frac{5}{12}, \frac{13}{30}, \frac{7}{15}$

$\frac{4}{20}, \frac{5}{12}, \frac{1}{10}, \frac{7}{15}, \frac{13}{30}$

$\frac{13}{30}, \frac{4}{20}, \frac{7}{15}, \frac{5}{12}, \frac{1}{10}$

$\frac{7}{15}, \frac{13}{30}, \frac{5}{12}, \frac{4}{20}, \frac{1}{10}$

20 Which diagram does not have  $\frac{1}{2}$  of the area shaded?

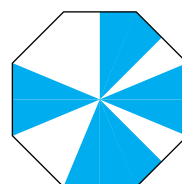
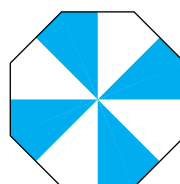
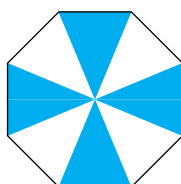
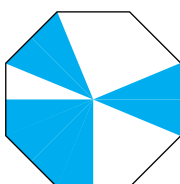



21 What fraction has the same value as  $3\frac{5}{8}$ ?

$\frac{8}{8}$



$\frac{29}{8}$



$\frac{19}{8}$



$\frac{43}{8}$



22 A water tank has a capacity of 5.32 kilolitres. How many litres does the water tank hold?

5.32



5320



53 200



532 000



23 What is the best estimate of the biggest angle in the triangle shown?

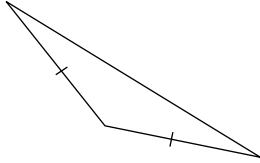

$170^\circ$



$160^\circ$



$140^\circ$



$97^\circ$



24 A rectangle has a width of 6m. Its length is twice its width.

The area of the rectangle is  m<sup>2</sup>

25 A triangular pyramid is cut as shown, and the top piece removed. The shape of the top face of the solid that is left is closest to

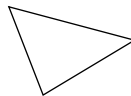
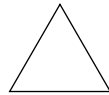
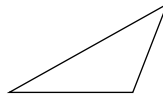
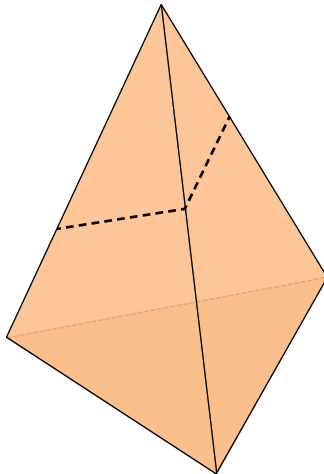

26 What is the value of  $x$  in this diagram?

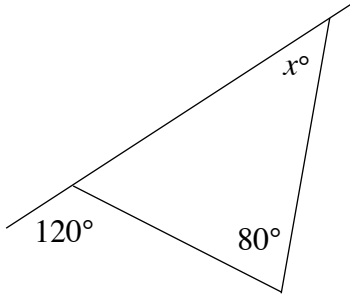

$70^\circ$

$60^\circ$

$50^\circ$

$40^\circ$

27

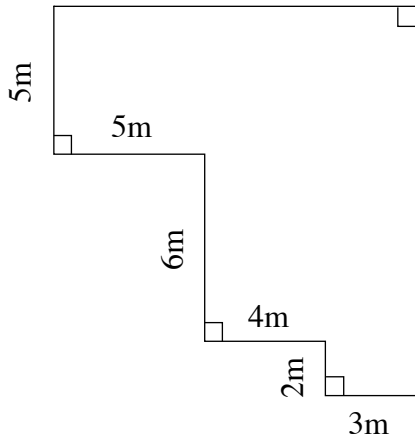

The perimeter of the shape is

metres.

28 Five softdrinks and \$5 worth of chips cost \$15.  
What would three softdrinks and \$4 worth of chips cost?

\$11.50

\$16

\$10

\$14.50

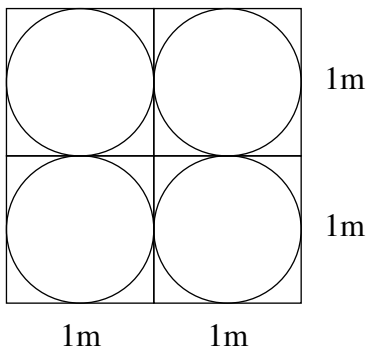

29



The tiles in the entry to a house are shaped as above.

The total area of the tiles which are not circles is   $\text{m}^2$  (to 3 decimal places)

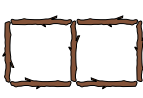
30 This square pattern is made with sticks

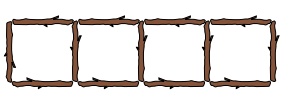
					...
No. of squares	1	2	3	4	9
No. of sticks	4	7	10	13	?

How many sticks make up 9 squares?

24



25



28



30



31 Two places are 8.2cm apart on a map. On the map 1cm represents 5km. The actual distance between the two places is

9km



40km



41km



42km



THIS PAGE IS INTENTIONALLY BLANK

## NAPLAN-style Numeracy Test A (non-calculator)

Remember to use a 2B pencil only.

### WARM-UP



*(non-calculator)*

- 1 Which number comes next in the sequence? 20, 30, 40, 50, .....

51

60

40

100

- 2 If  $a = 2$ ,  $b = 3$  and  $c = 6$ , the value of  $\frac{a^2b^2}{c}$  is

2

4

6

8

- 3 365cm equals  metres and  centimetres.

### PRACTICE TEST



*(non-calculator)*

- 1 Julia is drawing an isosceles triangle on a grid.

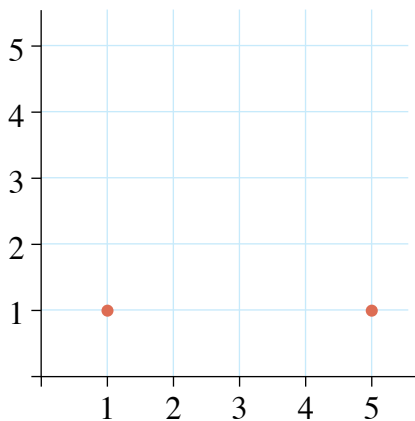

She has drawn the two end points of the base. The  $x$  value of the vertex is

1

2

3

4

- 2 Two towns are 120km apart. On a map with a scale of 1 : 2 000 000,

the towns would be  apart.

The next three questions apply to the table.

	Perth	Delhi	Johannesburg	Jakarta	Dilli	Bangkok	Phnom Penh	Darwin	Sydney
Perth		7 872	8 303	3 010	2 785	5 331	4 969	2 650	3 291
Delhi	7 872		8 038	5 002	6 628	2 917	3 444	7 348	10 425
Johannesburg	8 303	8 038		8 577	10 318	8 989	9 286	10 625	11 029
Jakarta	3 010	5 002	8 577		2 082	2 320	1 980	2 721	5 497
Dilli	2 785	6 628	10 318	2 082		1 646	3 194	720	3 845
Bangkok	5 331	2 917	8 989	2 320	1 646		536	4 430	7 531
Phnom Penh	4 969	3 444	9 286	1 980	3 194	536		3 910	7 026
Darwin	2 650	7 348	10 625	2 721	720	4 430	3 910		3 148
Sydney	3 291	10 428	11 029	5 497	3 845	7 531	7 026	3 148	

3 The closest city to Delhi is

- Johannesburg      Jakarta      Bangkok      Phnom Penh
- 

4 Janelle and Khi fly from Perth to Darwin and then Darwin to Phnom Penh, and then back to Perth.

The total distance they fly is  km

5 If a plane averages 700km/hr. The time taken to fly home from Johannesburg to Sydney would be approximately

- 15hrs                      16hrs                      17hrs                      18hrs
- 

6 Pat ate  $\frac{1}{2}$  his lollies before he got to his friend's house and then shared the other half with his two friends. If each friend got 5 lollies, the number Pat started with was

- 10                      20                      25                      30
- 

7 Sam has 120 marbles. The table shows the percentage of each colour.

Colour	Percentage
red	10
green	35
blue	25
white	30

The number of red marbles she has is

- 30                      20                      16                      12
-

8

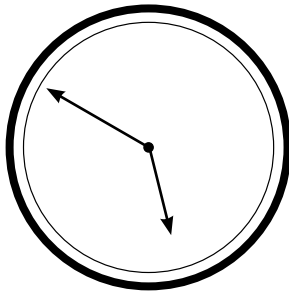

The time shown on the clock is

9 A movie starts at 3.05pm and runs for 105 minutes. It will finish at

4.40pm

4.10pm

4.50pm

5.20pm

10 Paul's mother asked him to buy the following items:

a kilo of potatoes, a 600g tin of soup, a 440g loaf of bread, a 250g container of yoghurt and 1.5kg of bananas.

The total weight of his purchases was

3.79kg

2.79kg

4.54kg

3.54kg

11 If Jake's mother gave him \$20, and the items cost \$15.35,

his change was

12 A piece of wood  $5\frac{3}{4}$  metres long is cut in half. Each piece measures

$2\frac{3}{8}$

$2\frac{7}{8}$

$2\frac{3}{4}$

$3\frac{1}{8}$

13 A six-sided die is numbered so that the sum of the opposite faces is always 7.

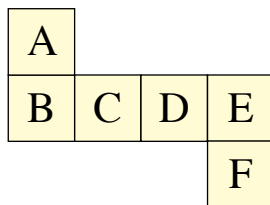

If face B is 4, which face should have a 3 on it?

C

D

E

F

14 A car travels at an average speed of 90km/hr. How long does it take to travel 495km?

6.5hrs



5.5hrs



5hrs



4.5hrs



15 A 45-minute lesson finishes at 12.25pm.

It starts at

16

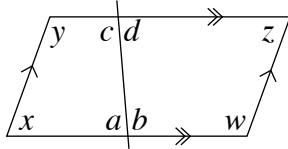

Which of the following is not true?

$x + d = a + z$

$a + b = c + d$

$x + y = w + z$

$x + a = b + w$

17

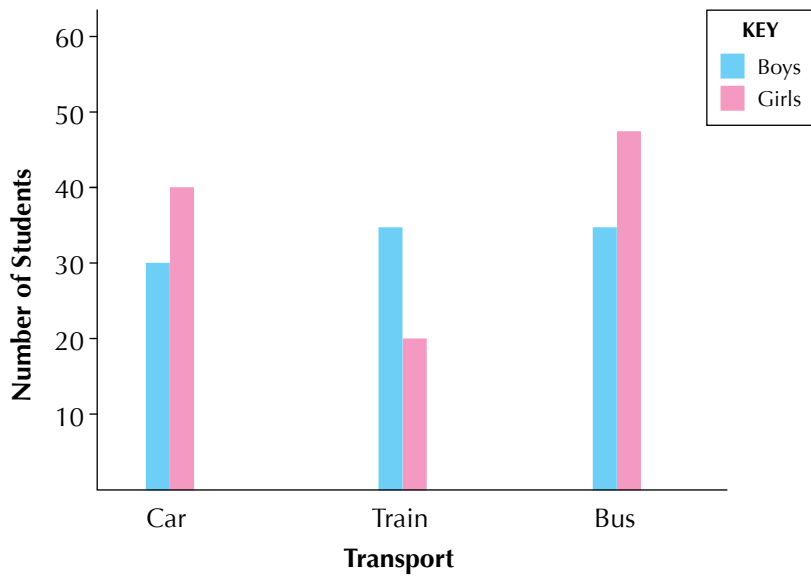

Use the information above to complete the table.

	Car	Train	Bus
Boys	30		35
Girls	40	20	47





18 Jaxon has a piece of cloth 7.8 metres long. He cuts 235cm from the cloth, the amount remaining is

6.45m

5.15m

5.45m

10.15m

19

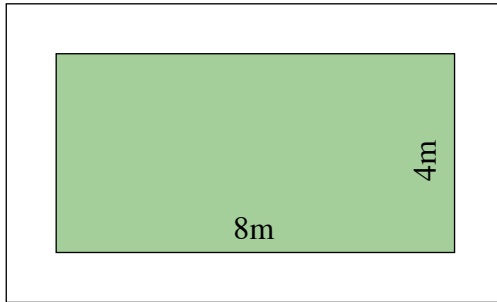

A garden 8m by 4m has a 1m tiled path around it. The tiles are 50cm  $\times$  50cm.

The number of tiles required to cover the path is  tiles.

20 The entry fees to an exhibition are adults \$4.50, children \$2.50 and pensioners \$1.50. A family of Mother, Father and 2 children, as well as the children's grandfather (who is a pensioner) would pay

\$8.50

\$10.00

\$15.50

\$17.50

21 Which number is greater than 0.07?

0.06

0.009

0.0076

0.3

22

$T_1$	$T_2$	$T_3$	$T_4$
1.1	2.2	3.3	4.4

If the pattern continues following the same

rule, the twelfth number in this pattern would be .

23 Use all the numbers 2, 3, 5, 7, 8, 9 once with some or all the operations  $\times$ ,  $\div$ ,  $+$ ,  $-$  and brackets to make the number 15.

24 An ancient civilisation used the following symbols for numbers

| one

∪ ten

☰ hundred

⊕ thousand

The number 3 234 would be written

25

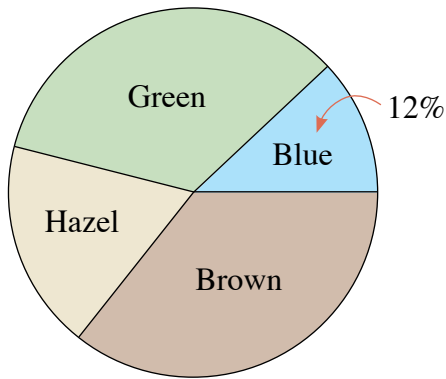

If there are 24 students with blue eyes, how many students are there in the grade?

200

240

150

180

26 If Matilda averaged 14 goals for her first 8 games, how many goals must she score in the next two games to average 15 for 10 games?

27 A number multiplied by itself and 7 added. If the result is 56, the number is

6

7

8

9

- 28 For the shape below, write the numbers 1, 2, 3, 4 and 5 so that each straight line adds up to 12.

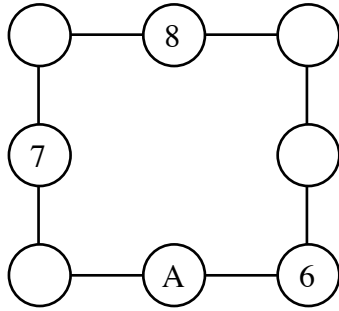

What number is A?

- 29 A bag contains 6 red balls, 8 green balls, and 12 blue balls.

How many black balls must be added so that the chance of getting a green ball is  $\frac{1}{4}$ ?

30

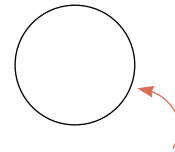
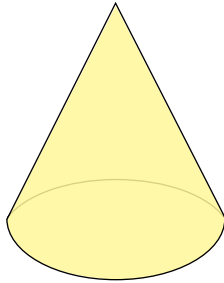

Select the shape which when added to this shape completes the net for the solid shown.



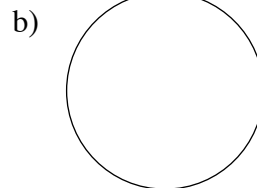

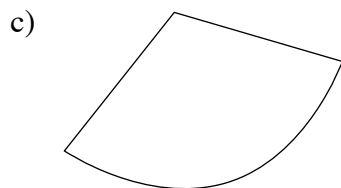

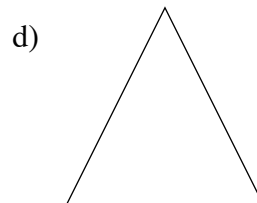

- 31 Grapes cost \$8 per kilo. Jack buys 300 grams. The amount he pays is

\$4.00

\$3.00

\$2.80

\$2.40

32 Which has the largest area?

a)

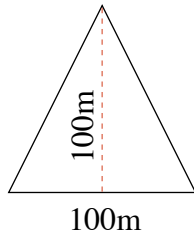

b)

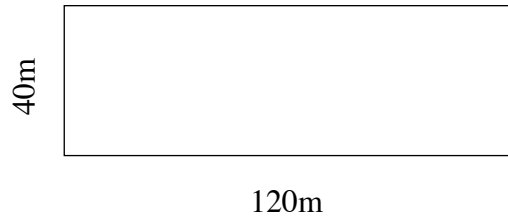

c)

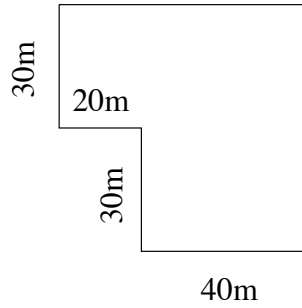

d)

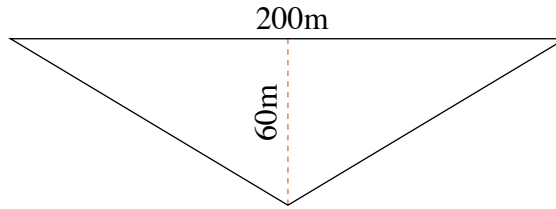

a



b



c



d



33 A fence is 30m long. Posts are placed 2.5m apart. The number of posts required is

11



12



13



14



# The Bell



Today you are going to write a narrative (a story).

The idea for your story is

**'The Bell'**.

Your story might be about the history of the bell or an historical event that happened at the bell.

It might be about the city the bell is in, and what the bell means to the residents who live there.

It could also be about a modern-day detective who discovers a long-lost mystery about the bell.

## REMEMBER:

- to plan your story before you start.
- to vary sentence structure.
- to choose interesting words.
- to write in paragraphs.
- to be careful with spelling.
- to edit when you have finished.

## THINK ABOUT:

- the characters in your story.
- where and when your story takes place.
- the complication or problem and how it is solved.
- how the story ends.

THIS PAGE IS INTENTIONALLY BLANK



Write a response to persuade the reader to agree with the following topic:

“I am a good role model for my brothers and sisters (or class mates).”

Remember the structure for persuasive writing:

- ✓ introduction
- ✓ body
- ✓ conclusion



Don't forget:

- to organise your ideas.
- to make your writing interesting and persuasive.
- to write in sentences, checking punctuation and spelling.
- to make sure you stay on topic and develop one idea in each paragraph.
- to check and edit your work.





THIS PAGE IS INTENTIONALLY BLANK